

ECLIPSE 5

WORLD CLASS 1/12TH PRO LMP CHASSIS

Driver: Sam Coult Track: Tamworth Event: BRCA LMP Nationals Stock Round 3
 Date: 25/02/23 Qualifying: 1 Final: 1 Best Lap: 12.06

TRACK TYPE

Grip Level High Medium Low
 Type Tight Open Mixed
 Condition Flat Bumpy Mixed
 Carpet Type
 Track Temp °C
 Weather

Notes:

TYRES

Side Wall Glue F: Y N
 Tyres Front: T35 Rear: T35
 Diameter Front: 40.5 mm Rear: 41.5 mm
 Additive Spider Blue Coverage Front: 9.5mm
 Additive On Time Front: 2min Rear: 1 round
Total time before the race starts
 Additive Off Time Front: race before Rear: race before
Total time the tyre is dry before the race
 Tyre Age Runs: 2 Time Between Runs

Notes:

FRONT

KEY: CF = Carbon Fibre, AL = Aluminium, P = Plastic, F = Front, R = Rear
 H = High, L = Low, Y = Yes, N = No, V = Vertical, H = Horizontal

Ride Height mm
 Droop mm
 Toe Out deg St Links mm
 Servo Saver Type
 Steering Travel in out
 Castor (+Ride Height Set) deg

 Notes:

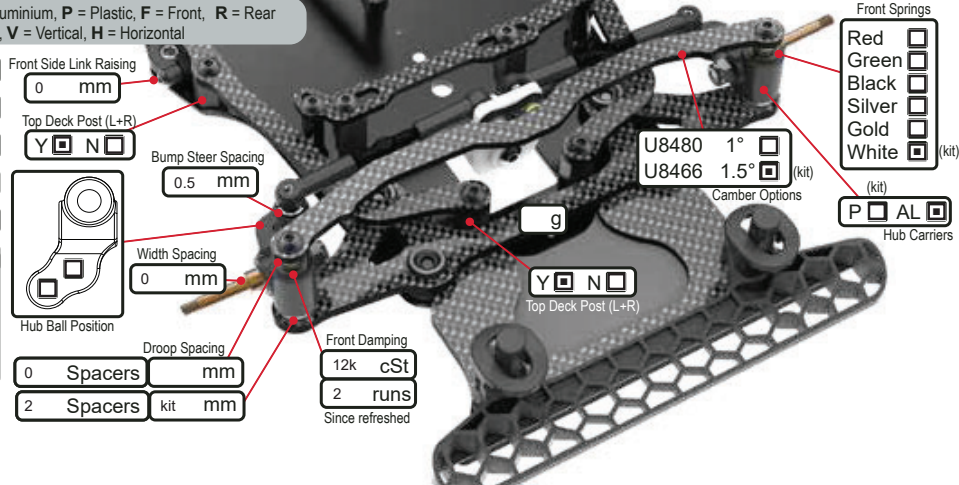

REAR

KEY: CF = Carbon Fibre, AL = Aluminium, P = Plastic, F = Front, R = Rear
 H = High, L = Low, Y = Yes, N = No, V = Vertical, H = Horizontal

Ride Height mm
 Droop mm
 Track width (total) mm
 Drive Type Diff Spool Hex
 Diff Preload (if applicable)
 Eccentric Height
 Pod Angle mm
 Kit = 4.2mm
 Notes:

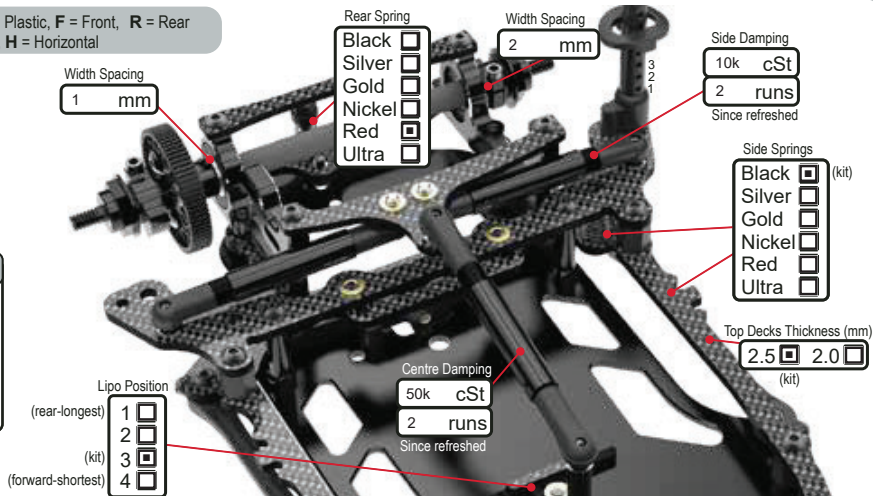

BODYSHELL

Body
 Rear Wing Height mm
 Front Height mm
 Front Post Hole #
 Front Post Hanger #
 Rear Post Hole #
 Rear Post Hanger #
 Body F/R Offset mm
 Body Weight g
 Foam Pads (U2840) F R
 Notes:

CHASSIS

Chassis AL CF
 Centre Pivot AL
 Spacing (kit) mm
 Total Weight g
 Weight Distribution F : R
 Motor Spacer mm
 Motor Fan
 Notes:

ELECTRONICS

E.S.C.
 Servo
 RX
 LiPo
 Motor
 Rotor Dia. mm
 Timing deg
 Gear Pitch 48 64
 Pinion t
 Spur t
 Rollout mm/rev

Notes: