

DRIVER DETAILS

NAME **Chris Grainger**
 DATE **March 2013**
 EVENT **Cotswold Testing**
 WEATHER **Dry/Cold**
 RESULT **NIA**

NOTES

Mi5

Schumacher
 racing-cars.com

CHASSIS AND ELECTRICS

CHASSIS **Std Kit** Rear Motor Mid Motor
 TOP DECK **Std Kit**
 BODYSHELL **Protoform LTC**
 WING **MR-33**
 E.S.C **GM-120**
 SERVO **KO**
 RECIEVER **KO**
 CELLS **GM**
 CELL POSITION Forward Middle Rearward

MOTOR AND GEARING

MOTOR **GM 5.5T**
 ROTOR DIAMETER **12.5**
 TIMING **Std**
 GEAR PITCH 48DP 64DP
 SPUR SIZE **89T**
 PINION SIZE **22T**

TRACK CONDITIONS

GRIP LEVEL High Medium Low
 TYPE Tight Open Mixed
 SURFACE Carpet Tarmac
 CONDITION Smooth Bumpy
 TEMPERATURE **8 °C** °F
 VENUE Indoor Outdoor

WHEELS, TYRES AND INSERTS

WHEELS **Revlite**
 TYRES **Sorex 32R**
 INSERTS **Yellow BRCA**
 TYRE ADDITIVE **MR-33**
 ADDITIVE TIME Front **15** Minutes Rear **15** Minutes
 TYRE WARMERS Yes No Temp **60 °C** Time **15** Minutes

REAR



Drop **4.0** mm
 On 10mm Block
 Ride Height **6.0** mm
 Camber **-2.0** Degree's

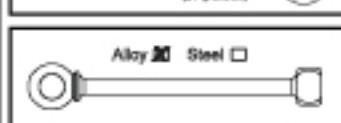
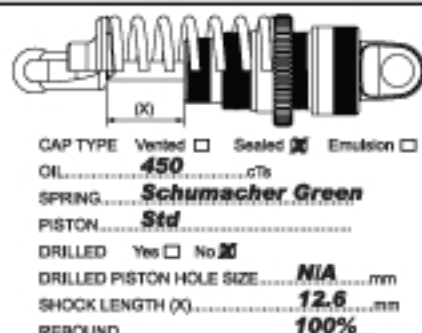
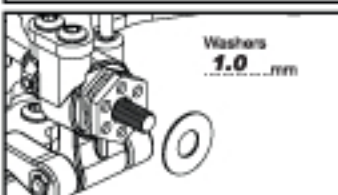

FRONT

