

### DRIVER DETAILS

NAME **Chris Grainger**  
 DATE **March 2013**  
 EVENT **Carpet Testing**  
 WEATHER **NIA**  
 RESULT **NIA**

### NOTES

# Mi5

**Schumacher**  
 racing-cars.com

### CHASSIS AND ELECTRICS

CHASSIS **Std Kit** Rear Motor  Mid Motor   
 TOP DECK **Std Kit**  
 BODYSHELL **Speed 6**  
 WING **MR-33**  
 E.S.C **GM-120**  
 SERVO **KO**  
 RECIEVER **KO**  
 CELLS **GM**  
 CELL POSITION Forward  Middle  Rearward

### MOTOR AND GEARING

MOTOR **GM 10.5T**  
 ROTOR DIAMETER **12.3**  
 TIMING **+10 deg**  
 GEAR PITCH 48DP  64DP   
 SPUR SIZE **89T**  
 PINION SIZE **23T**

### TRACK CONDITIONS

GRIP LEVEL High  Medium  Low   
 TYPE Tight  Open  Mixed   
 SURFACE Carpet  Tarmac   
 CONDITION Smooth  Bumpy   
 TEMPERATURE **15 °C**  °F   
 VENUE Indoor  Outdoor

### WHEELS, TYRES AND INSERTS

WHEELS **Revlite**  
 TYRES **Sorex 28R**  
 INSERTS **JB**  
 TYRE ADDITIVE **Nosram carpet**  
 ADDITIVE TIME Front **10** Minutes Rear **10** Minutes  
 TYRE WARMERS Yes  No  Temp °C Time Minutes

### REAR

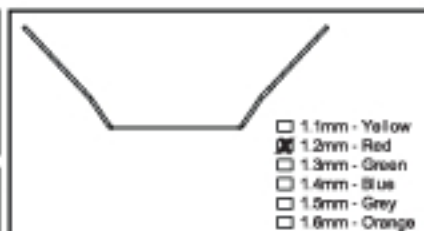

Drop **4.5** mm  
 On 10mm Block   
 Ride Height **5.2** mm  
 Camber **-2.0** Degree's

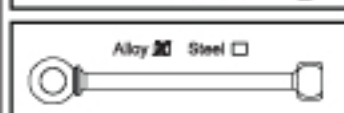
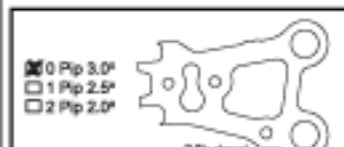
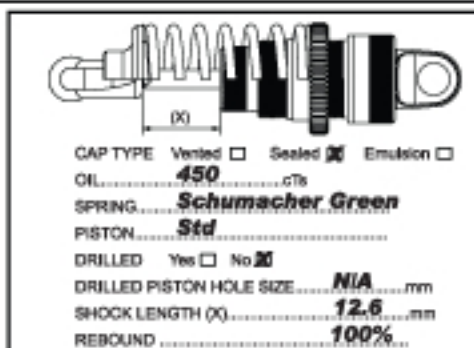
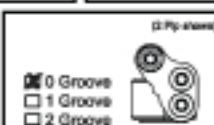
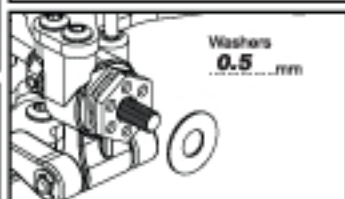

### FRONT

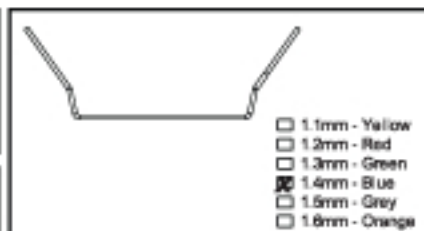

Drop **5.0** mm  
 On 10mm Block   
 Ride Height **5.0** mm  
 Camber **-2.0** Degree's  
 Toe-in ..... Degree's  
 Toe-out **1** Degree's

